

Specifications

Environment	Digital Audio, LPCM
Devices	DVD, CD Players, TV, PC, laptops.
Transmission	Transparent to the user
Signals	2 channel LPCM (Linear Pulse Code Modulation)
Connectors	One (1) Coaxial connector One (1) TOSLink Connector. Two (2) RCA Connectors. <i>Note: TOSLink cable included. RCA cables not included.</i>
Switch	Selects between SPDIF and TOSlink
Distortion	<0.001% @ 1KHz
SNR	> 90 dB (20Hz – 20 KHz)
Sample Rate	32, 44.1, 48 and 96 KHz
Bit Depth	24 bit S/PDIF bitstream on right and left channels
Power Supply	One (1) 110-240V/5VDC power supplies with interchangeable blades
Power Consumption	0.75 Watt
Temperature	Operating: 0° to 40°C Storage: -20° to 85°C Humidity: Up to 95% non-condensing
Enclosure	ABS fire retardant plastic
Dimensions	2.4" x 2.25" x 1.0" (6.1 x 5.5 x 2.5 cm)
Weight	1.0 lb (0.45 kg)
Mounting	Velcro pads included.
Compliance	Regulatory: FCC, CE, RoHS Flammability: 94V0
Warranty	2 years
Order Information	500080 Digital Audio Converter, LPCM



Digital Audio Converter, LPCM 500080

Quick Installation Guide

Overview

The Digital Audio Converter, LPCM (500080) converts one LPCM-encoded coaxial (S/PDIF) or optical (TOSLink) digital audio signal to a standard left/right analog audio output, thereby allowing a digital audio source such as a DVD or CD player without RCA analog audio output to be connected to an audio-video receiver or TV.

Applications

Applications include commercial and residential audio systems, boardroom systems, collaborative PC systems, and medical information systems.



8495 Dalton Road, Mount Royal, Quebec, Canada. H4T 1V5
Tel: (514) 905-0588 Fax: (514) 905-0589
Toll Free (North America): (877) 689-5228
E-mail: videoease@muxlab.com URL: www.muxlab.com

Installation

1. Identify the connectors on the Digital Audio Converter as indicated on the product panels.



2. To install the Digital Audio Converter:
 - 3a. Connect the converter input to the digital audio source with an Optical (TOSLink) or 75-ohm coaxial (S/PDIF) cable.
 - 3b. Set the input switch to the appropriate signal.
 - 3c. Connect the converter output to the analog audio receiver with a stereo audio compliant cable.
3. Connect the 5 VDC power supply to the converter first, and then plug the power supply into an AC power outlet. If power is present, the green power LED of the Digital Audio Converter will be ON.

Note: Power-on the Digital Audio Converter only after all connections are made.

4. Power-on the audio source and receiver and verify the image quality.
5. The following diagrams shows the final configuration.

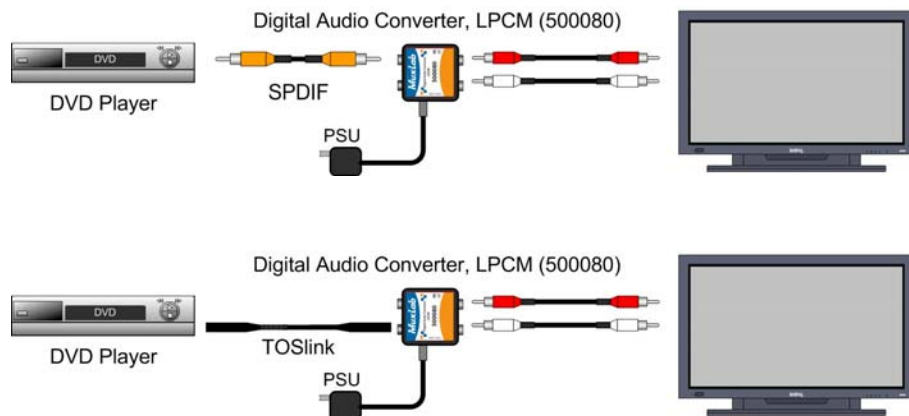

Troubleshooting

The following table describes some of the symptoms, probable causes and possible solutions in regard to the installation of the Digital Audio Converter:

Symptom	LEDs		Probable Cause	Possible Solutions
	Power	Lock		
No Sound	OFF	OFF	No power	• Check power connections
No Sound	ON	OFF	Optical/Coaxial Cable	• Check the Optical/Coaxial cables.
No Sound	ON	ON	Stereo audio cable	• Check the stereo audio cable.
No Sound	ON	ON	Wrong input on receiver	• Check if the selected input on the receiver can receive analog stereo audio.
Noise	ON	ON	Audio source outputs a compressed bitstream such as Dolby Digital/DTS	• Configure the source to only output an uncompressed LPCM bitstream
Choppy sound	ON	ON	Weak Connections	• Check cable connection • Check the Optical/Coaxial Cable Quality.

If you still cannot diagnose the problem, please call MuxLab Customer Technical Support at 877-689-5228 (toll-free in North America) or (+1) 514-905-0588 (International).